

SME Expo Transport Infrastructure 2009
(August 19th – 21st, 2009)
At the Bombay Exhibition Centre, Mumbai



SME Expo Transport Infrastructure 2009 is a highly specialized trade exhibition for the infrastructure companies and a platform to facilitate effective interaction among several fraternities of the Transport Industry.

The event is designed to showcase latest projects, solutions/services & technologies for building Transport Infrastructure and a platform for exploring more business opportunities and dissemination of knowledge in the quest to deliver world class services.

The event encompasses of 3 day exhibition & 2 days of parallel conference:

- **3 Day Exhibition** will provide opportunities of displaying of products & services, positioning & repositioning, strengthening clientele relations, brand enhancement, researching & analyzing market trends, promoting the projects undertaken, etc.
- **2 Day Conference** will provide a platform to gauge opportunities, learn case studies & best practices and discuss issues for industry benefit, modification to the social & business responsibility, etc.
- **Key Exhibitors Profile:**
 Infrastructure Developers /Construction Companies, Engineering & Design Consultants, Construction Equipments & Vehicles, IT Infrastructure Companies, etc
- **Key Visitors Profile:**
 Ministry of Civil Aviation, Ministry of Shipping, Road Transport & Highways, Ministry of Railways, Port Authorities, Airport Authorities, Airline / Aircraft Operators, Ship Owners, Corporates, Architects, Government Organizations, etc

The above tradeshow will be held in conjunction with 4th edition of SME Expo Logistics & Material Handling 2009

CONTACT
 (For Stall booking & Conference registration)

Fax: 91 22 28765444
 Mobile : 91 9322754288
 Email: daisy@inis-enterprises.com
 Alternate Email: daiz17_ann@rediffmail.com



presents



19th - 21st August, 2009 | Bombay Exhibition Centre, Mumbai, India

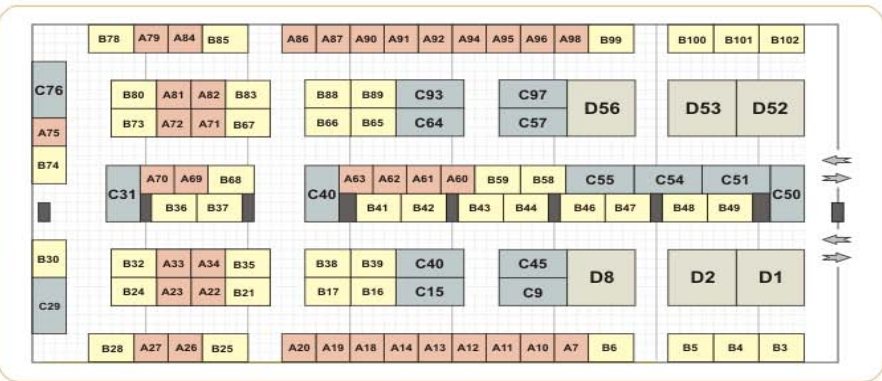

STANDARD BOOTH SIZES / FURNITURE / ELECTRICALS					
STALL TYPE	AREA (SQ.MTS.)	TABLE	CHAIR(s)	SPOT LIGHT(s)	PLUG POINT(s)
A	9	1	2	2	1
B	12	1	2	3	1
C	16	2	4	6	2
D	24	4	8	12	4

INDOOR BOOTH CHARGES	
National Participants	Shell Scheme Stall (Min. Area 9 sq.mts) @ Rs. 9500 per sq.mtr.
International Participants	Shell Scheme Stall (Min. Area 9 sq.mts) @ USD 300 per sq.mtr.

15% EXTRA FOR CORNER BOOTHS.
 100% PAYMENT WITH CONFIRMATION
 GOVT TAXES EXTRA - 12.36% (SERVICES TAX 12%, EDUCATION CESS ON SERVICE TAX 2% AND SECONDARY & HIGHER SECONDARY CESS ON SERVICE TAX 1%)
 The Organizers reserve the right to modify the floorplan under circumstances beyond their control.